

## JSY-MK-194T Single-phase two-way electric energy measurement module

### 1. Product description

- 1.1 Introduction
- 1.2 Functional features
- 1.3 Technical parameters

### 2. Application

- 2.1 Appearance and installation
- 2.2 Interface definition
- 2.3 Application instructions
- 2.4 Electric energy measurement function

### 3. Modbus register

### 4. MODBUS communication protocol

### 5. Precautions

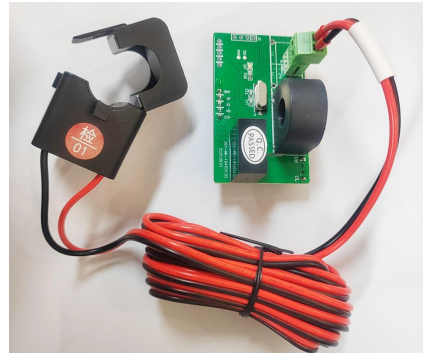

## 1. Product introduction

### 1.1. Introduction

JSY-MK-194T single-phase two-channel electric energy measurement module is a single-phase AC parameter measurement product that highly integrates measurement and digital communication technology and can complete electric energy measurement, collection and transmission. It can accurately measure two-channel single-phase AC voltage, Electrical parameters such as current, power, power factor, frequency, electricity, etc., 1-way TTL level interface, completely isolated circuit, small size, simple interface, can be easily embedded into various equipment that need to measure power consumption, and has excellent value for money.

JSY-MK-194T single-phase two-way electric energy metering module can be widely used in energy-saving transformation, new energy charging piles, electric power, communications, railways, transportation, environmental protection, petrochemicals, steel and other industries to monitor the current and Power consumption.

## 1.2. Features

- 1.2.1. Collect single-phase and two-channel alternating current parameters, including voltage, current, power, factor, frequency, electric energy and other electrical parameters.
- 1.2.2. Adopt special measurement chip, effective value measurement method, high measurement accuracy.
- 1.2.3. With 1-way TTL communication interface, compatible with 5V/3.3V interface.
- 1.2.4. The communication protocol adopts Modbus-RTU, which has good compatibility and facilitates programming.
- 1.2.5. High isolation voltage, withstand voltage up to DC3000V.

## 1.3. Technical Parameters

### 1.3.1 Single phase AC input

- 1) Voltage range: 1~300V (can be customized).
- 2) Current range: 20mA~50A (can be customized).
- 3) Signal processing: using special measurement chip, 24-bit AD sampling.
- 4) Overload capacity: 1.2 times the current range is sustainable, and 1.5 times the voltage range is not damaged.
- 5) Input impedance: voltage channel > 1 kΩ/V.

### 1.3.2 Communication Interface

- 1) Interface type: 1-way TTL communication interface, compatible with 5V/3.3V.
- 2) Communication protocol: MODBUS-RTU protocol.
- 3) Data format: The default is "n,8,1", "e,8,1", "o,8,1", "n,8,2" can be set.
- 4) Communication rate: The default is 4800bps, 9600bps, 19200bps can be set.

### 1.3.3 Measurement output data

For multiple electrical parameters such as voltage, current, power, electric energy, power factor, frequency, etc., see the Modbus data register list.

### 1.3.4 measurement accuracy

Voltage, current, power, electricity: less than ± 1.0 %.

### 1.3.5 Isolation

The power supply under test and the power supply are isolated from each other. the isolation withstand voltage is 3000VDC.

**1.3.6 power supply**

- 1) DC single power supply 3.3~5V power supply, power consumption 10mA.

**1.3.7 working environment**

- 1) Working temperature: -40~+80℃ .
- 2) Relative humidity: 5~95%, no condensation (at 40℃ ) .
- 3) Altitude: 0~3000 meters.
- 4) Environment: No explosive, corrosive gases and conductive dust, no significant shaking, vibration and impact.

**1.3.8 Temperature drift:** ≤100ppm/℃ .

**1.3.9 Installation method:** PCB welding.

**1.3.10 Module size :** 60.48\*36.81\*28mm (length\*width\*height)

**2. Application**

**2.1、 Appearance and installation**

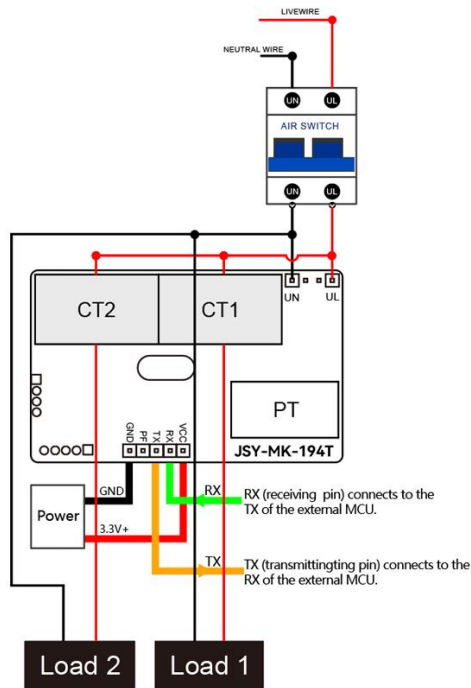

Figure 2.1 Wiring Diagram

**2.2、 Interface definition**

2.2.1 Pin description

logo	characteristic	Function description
U L	Live line	Measured voltage live wire connection port
U N	Neutral line	Measured voltage neutral line connection port
VCC	Power+	Metering module power supply pin , normal application range: 3.3 V-5V
RX	enter	Module TTL level receiving pin
Tx	output	Module TTL level sending pin
PF	output	Active energy verification pulse output, low level output by default, generally does not need to be connected to this pin, but the pin position must be reserved
GND	power supply-	power ground

**2.3、 Application Notes**

Please refer to the above diagram for correct wiring according to product specifications and models. Make sure to disconnect all signal sources before wiring to avoid danger and damage to the equipment. After checking to confirm that the wiring is correct, turn on the power and test.

After the power is turned on, the "indicator light " is always on, and during communication, the "indicator light" flashes synchronously during communication data transmission.

When the product leaves the factory, it is set to the default configuration: address No. 1, baud rate 4800bps, data format "n,8,1", data update rate is 330ms once, and the transformation ratio is 1.

You can use the JSY-MK-194T series product testing software we provide to change the settings of product parameters and general testing of the product.

**2.4、 Electric energy measurement function**

Can provide single-phase voltage, current, power, power factor, frequency, active energy

and other parameters.

The electricity data is a 4-byte unsigned number. It will not overflow for 10 consecutive years and the data will be saved when the power is turned off.

### 三、JSY-MK-194T Modbus register list

**Table 1: System configuration parameter register address (Function code:03H-read, 10H-write)**

Number	Definition	Register address	Read/write	Description
1	ID and baud rate	0004H	Read/write	Default value:0105H (default ID is 01H, default communication format is 8, N, 1,4800bps) explain: High byte is ID,it can be set as 1 to 255. Low byte is baud rate, 3-1200bps, 4-2400bps, 5—4800bps, 6—9600bps, 7-19200bps, 8-38400bps

**Table 2: System parameter (Function code:03H-read,read only)**

Number	Definition	Register address	Read/write	Description
1	Model 1	0000H	Read	Value is 0194H
2	Model 2	0001H	Read	Reserved
3	Voltage range	0002H	Read	Value is 250(V)
4	Current range	0003H	Read	Value is 800 (800/10=80A)

**Table 3:Measuring electrical parameter register (Function code:03H-read, 10H-write)**

Number	Definition	Register address	Read/write	Byte length	Description
1	First channel voltage	0048H	Read	4	Unsigned, Value=DATA/10000 (V)
2	First channel current	0049H	Read	4	Unsigned, Value=DATA/10000 (A)
3	First channel active power	004AH	Read	4	Unsigned, Value=DATA/10000 (W)
4	Positive active energy of first channel	004BH	Read/Write	4	Unsigned, Value=DATA/10000 (kWh)
5	First channel power factor	004CH	Read	4	Unsigned, Value=DATA/1000
6	Negative active energy of first channel	004DH	Read/Write	4	Unsigned, Value=DATA/10000 (kWh)
7	Power direction	004EH	Read	4	First byte(first channel): 00-positive,01-negative. Second byte(second channel):00-positive,01-negative
8	Frequency	004FH	Read	4	Unsigned, Value==DATA/100(Hz)
9	Second channel voltage	0050H	Read	4	Unsigned, Value=DATA/10000 (V)
10	Second channel current	0051H	Read	4	Unsigned, Value=DATA/10000 (A)
11	Second channel active power	0052H	Read	4	Unsigned, Value=DATA/10000 (W)
12	Positive active energy of second	0053H	Read/Write	4	Unsigned, Value=DATA/10000 (kWh)

	channel				
13	Second channel power factor	0054H	Read	4	Unsigned, Value=DATA/1000
14	Negative active energy of second channel	0055H	Read/Write	4	Unsigned, Value=DATA/10000 (kWh)

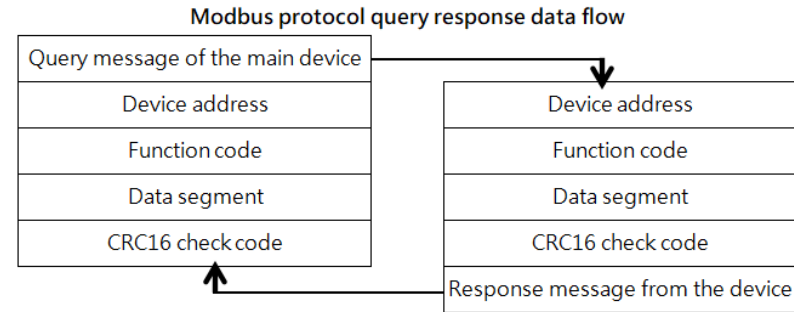

#### 四、MODBUS Communication Protocol

This instrument provides a serial asynchronous half-duplex RS485 communication interface, using the standard MODBUS-RTU protocol, and various data information can be transmitted on the communication line. Up to 255 network instruments can be connected to one line at the same time. Each network instrument can set its communication address. The communication connection should use a shielded twisted pair with a copper mesh, and the wire diameter should not be less than 0.5mm<sup>2</sup>. When wiring, communication lines should be kept away from strong current cables or other strong electric field environments.

The MODBUS protocol adopts the master-slave response communication connection method on one communication line. First, the signal from the host computer is addressed to a terminal device (slave) with a unique address. Then, the response signal from the terminal device is transmitted to the host in the opposite direction, that is, the signal is transmitted along a separate communication line. All communication data streams are transmitted in opposite directions (half-duplex operating mode). The MODBUS protocol only allows communication between the host (PC, PLC, etc.) and terminal devices, but does not allow data exchange between independent terminal devices. In this way, each terminal device will not occupy the communication line when they are initialized, but is limited to responding. Query signal arriving at this machine.

Host query: The query message frame includes device address, function code, data information code, and check code. The address code indicates the slave device to be selected. the function code tells the selected slave device what function it wants to perform. For example, function code 03 or 04 requires the slave device to read registers and return their contents. the data segment contains the requirements of the slave device. Any additional information to perform the function, the check code is used to verify the correctness of a frame of information, the slave device provides a method to verify whether the message content is correct, it uses the calibration rule of CRC16.

Slave response: If the slave device generates a normal response, the response message contains the slave address code, function code, data information code and CRC16 check code. Data information codes include data collected from the device: like register values or status. If an error occurs, we agree that the slave machine will not respond.

We specify the communication data format used in this instrument: bits per byte (1 start bit, 8 data bits, odd or even parity or no parity, 1 or 2 stop bits) .

The structure of the data frame, that is, the message format:

Device address	function code	data segment	CRC16 check code
1 byte	1 byte	N bytes	2 bytes (low byte first)

Device address: It consists of one byte. The address of each terminal device must be unique. Only the addressed terminal will respond to the corresponding query.

Function code: tells the addressed terminal what function to perform. The following table lists the function codes supported by this series of instruments and their functions.

function code	Function
03H	Read the value of one or more registers
10H	Write the value of one or more registers
01H	Read the output status of relay 1
05H	Write the output status of relay 1

Data segment: Contains the data required by the terminal to perform specific functions or the data collected when the terminal responds to queries. The content of these data may be numerical values, reference addresses or setting values.

Check code: CRC16 occupies two bytes and contains a 16-bit binary value. The CRC value is calculated by the transmitting device and then appended to the data frame. The receiving device recalculates the CRC value when receiving the data and then compares it with the value in the received CRC field. If the two values are not equal, an error occurs. mistake.

The process of generating a CRC16 is:

- (1) Preset a 16-bit register to 0FFFFH (all 1s), called CRC register.
- (2) Perform XOR operation on the 8 bits of the first byte in the data frame and the low byte in the CRC register, and store the result back into the CRC register.
- (3) Shift the CRC register one bit to the right, fill the highest bit with 0, shift out the lowest bit and detect it.
- (4) If the lowest bit is 0: repeat the third step (next shift). if the lowest bit is 1: perform an XOR operation on the CRC register and a preset fixed value (0A001H).
- (5) Repeat steps 3 and 4 until 8 shifts. In this way, a complete eight bits are processed.
- (6) Repeat steps 2 to 5 to process the next eight bits until all bytes are processed.
- (7) The final value of the CRC register is the value of CRC16.

### MODBUS-RTU communication protocol example:

#### 4.1. Function code 0x03: Read multiple registers

Example: The host wants to read 2 slave register data with address 01 and start address 0048H.

Host sends: 01 03 00 48 00 02 CRC

Address function code starting address data length CRC code

Slave response: 01 03 04 12 45 56 68 CRC

Address function code returns the number of bytes Register data 1 Register data 2 CRC code

#### 4.2. Function code 0x10: Write multiple registers

Example: The host wants to save 0000,0000 to the slave register with addresses 000C, 000D (slave address code is 0x01)

Host sends: 01 10 00 0C 00 02 04 00 00 00 00 F3 FA

Address function code starting address number of write registers byte count saved data 1 2 CRC code

Slave response: 01 10 00 0C 00 02 81 CB

Address function code starting address write register number CRC code

#### 4.3. Description

The register in the MODBUS-RTU communication protocol refers to 16 bits (ie 2 bytes), and the high-order bit is first.

When setting parameters, be careful not to write illegal data (that is, data values that exceed the data range limit).

The error code format returned by the slave is as follows:

Address code: 1 byte

Function code: 1 byte (the highest bit is 1)

Error code: 1 byte

CRC: 2 bytes

The response returns the following error code:

81: Illegal function code, that is, the received function code module does not support it.

82: Reading or writing illegal data address, that is, the data location exceeds the readable or writable address range of the module.

83: Illegal data value, that is, the data value sent by the module received by the host exceeds the data range of the corresponding address.

#### 4.4. Example of command analysis:

4.4.1 Read electrical parameter instructions (take the module address as 0x01 as an example):

Send data: 01 03 00 48 00 0E 44 18 (read 14 registers starting from 0048H)

Received data: 01 03 38 00 24 1E F9 00 05 FE A3 05 8D 37 68 00 00 4F 38 00 00 03 E8 00 00 3D F1 00 00 00 00 00 00 13 89 00 24 1E F9 00 05 FE B9 05 8B 67 18 00 00 4E CA 00 00 03 E8

00 00 3D A2 C1 9E (The red part is the data corresponding to the 0048H start register),

4.4.2 Clear power command (take module address 0x01 as an example):

Clear the first electric energy:

Send data: 01 10 00 4B 00 02 04 00 00 00 00 B6 2C

Receive data: 01 10 00 4B 00 02 31 DE

Clear the second electric energy:

Send data: 01 10 00 53 00 02 04 00 00 00 00 B6 86

Receive data: 01 10 00 53 00 02 B1 D9

Clear two channels of power at the same time:

Send data: 01 10 00 0C 00 02 04 00 00 00 00 F3 FA

Receive data: 01 10 00 0C 00 02 81 CB

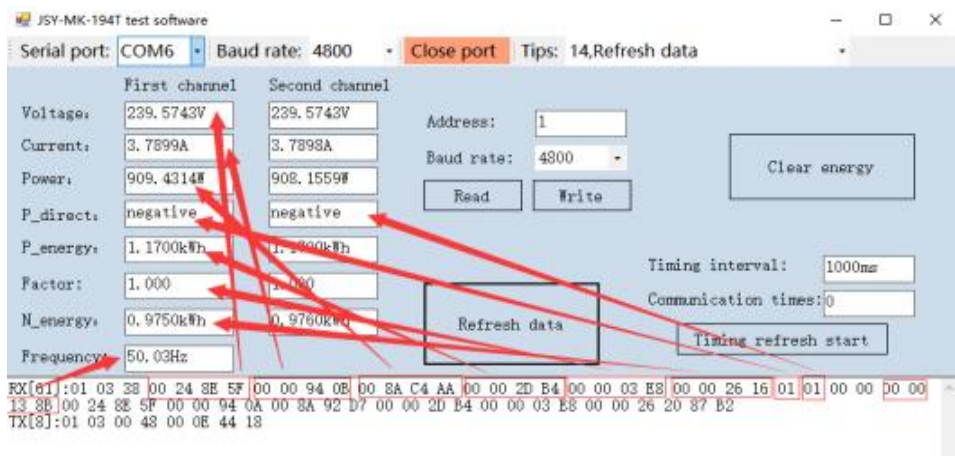

## 5. Precautions

- 1) Pay attention to the auxiliary power information on the product label. Do not connect the wrong auxiliary power level and polarity of the product, otherwise the product may

be damaged.

- 2) Please refer to the diagram for correct wiring according to product specifications and models. Make sure to disconnect all signal sources and power before wiring to avoid danger and damage to the equipment. After checking to confirm that the wiring is correct, turn on the power and test.
- 3) The voltage circuit or the secondary circuit of the PT must not be short-circuited.
- 4) When there is current on the primary side of the CT, it is strictly forbidden to open the secondary circuit of the CT. It is strictly forbidden to make live connections or unplug terminals.
- 5) When using the product in an environment with strong electromagnetic interference, please pay attention to the shielding of the input and output signal lines.
- 6) When installed in a centralized manner, the minimum installation interval should not be less than 10mm.
- 7) This series of products does not have a lightning protection circuit inside. When the input and output feeders of the module are exposed to harsh outdoor weather conditions, lightning protection measures should be taken.
- 8) Please do not damage or modify the product's label or logo, and do not disassemble or modify the product, otherwise our company will no longer provide "three guarantees" (guaranteed replacement, guaranteed return, and guaranteed repair) service for the product.

Manufacturer: Shenzhen Jiansiyan Technologies Co., Ltd.

Online Technical Support Staff:

+86 18675534520(Mr.Jahleel)

+86 18665924579(Mr.Jimmy)

E-mail: jsykj@outlook.com

Web: www.jsypowermeter.com

Address: 901, Building 1, Taijiale Technology Industrial Park, Tongguan Road, Tianliao Community, Yutang Street, Guangming District, Shenzhen, Guangdong, 518100, China.



official website