

JSY-MK-339 AC Three Phase Energy Meter Monitor

Menu

1. Product introduction

- 1.1 Introduction
- 1.2 Functional features
- 1.3 Technical parameters

2. Application

- 2.1 Appearance and installation
- 2.2 Terminal definition
- 2.3 Typical wiring
- 2.4 Application instructions

3. Modbus register

4. Modbus communication protocol

5. Precautions



1. Product introduction

1.1. Introduction

JSY-MK-339 three-phase voltage and current collector is a three-phase power quality detection device with completely independent intellectual property rights developed by our company using microelectronics technology and special large-scale integrated circuits, and applying advanced technologies such as digital sampling processing technology and SMT technology. instrument. This collector complies with the relevant technical requirements of Class 1 three-phase active energy meters in the IEC 62053-21 national standard, and can directly and accurately measure the voltage, current, power, power factor, and electricity in a three-phase AC power grid with a rated frequency of 50HZ or 60HZ. and total isoelectric

parameters. The collector has 1 RS485 communication interface and Modbus-RTU communication protocol to facilitate connection with various AMR systems. It has the characteristics of good reliability, small size, light weight, beautiful appearance, and easy installation.

JSY-MK-339 three-phase voltage and current collector can be widely used in energy-saving renovation , electric power, communications, railways, and transportation, environmental protection, petrochemical, steel and other industries, used to monitor the current and power consumption of AC equipment.

1.2. Features

- 1.2.1. Collect three-phase alternating current parameters, including voltage, current, power, electric energy and other electrical parameters, with complete information.
- 1.2.2. Adopt special measurement chip, effective value measurement method, high measurement accuracy.
- 1.2.3. With 1 RS485 interface.
- 1.2.4. With 1 residual current measurement interface.
- 1.2.5. The communication protocol adopts standard Modbus-RTU, which has good compatibility and facilitates programming.
- 1.2.6. Dot matrix LCD display.
- 1.2.7. Wide working voltage AC 80~240V.
- 1.2.8. It adopts industrial-grade chips, built-in watchdog, and has complete lightning protection and anti-interference measures to ensure reliability.
- 1.2.9. High isolation voltage, withstand voltage up to AC: 2000V.
- 1.2.10. Optional single-turn through-core transformers or open-close type transformers of different specifications are available, which are convenient and easy to use.

1.3. Technical parameters

1.3.1 Three-phase AC input

- 1) Voltage range: 100V, 220V, 380V, etc. optional.
- 2) Current range: 50A, 100A, 250A, 500A, etc. are optional. external enclosed or split-core current transformer models are optional.

- 3) Signal processing: using special measurement chip, 24-bit AD sampling.
- 4) Overload capability: 1.2 times the range is sustainable. instantaneous ($<200\text{ms}$) current is 5 times, voltage is 2 times the range without damage.
- 5) Input impedance: voltage channel $>1\text{ k}\Omega/V$. current channel $\leq 100\text{m}\Omega$.

1.3.2 Switching output

1 channel, relay open circuit output, voltage and current overload alarm protection output function.

1.3.3 Communication interface

- 1) Interface type: Provide 1 RS-485 interface.
- 2) Communication protocol: Modbus-RTU protocol.
- 3) Data format: can be set by software, "n,8,1", "e,8,1", "o,8,1", "n,8,2".
- 4) Communication rate: The baud rate of the RS-485 communication interface can be set to 1200, 2400, 4800, 9600Bps. the factory default baud rate is 9600bps, and the data format is "n,8,1".
- 5) Communication data:

Multiple electrical parameters such as voltage, current, power, electric energy, etc., see Mdbus data register list

1.3.4 Measurement accuracy

Voltage, current, power: $\pm 1.0\%$. active electricity level 1

Isolation: RS-485 interface, isolated from AC power supply, voltage input, and current input. isolation withstand voltage 2000VDC.

1.3.5 power supply

- 1) Optional 100V, 220V, 380V, voltage line 100V~380V

When powered by AC220V, the peak voltage shall not exceed 265V. typical power consumption: $\leq 2\text{W}$.

1.3.6 working environment

- 1) Working temperature: $-20\sim+60^\circ\text{C}$. Storage temperature: $-40\sim+85^\circ\text{C}$.
- 2) Relative humidity: 5~95%, no condensation (at 40°C).
- 3) Altitude: 0~3000 meters.
- 4) Environment: No explosive, corrosive gases and conductive dust, no significant shaking, vibration and impact.

1.3.7 Temperature drift: $\leq 100\text{ppm}/^\circ\text{C}$.

1.3.8 Installation method: 4P guide rail installation.

1.3.9 Module size: $72*58*92\text{ mm}$

2. Application

2.1、80A, 100A transformer appearance

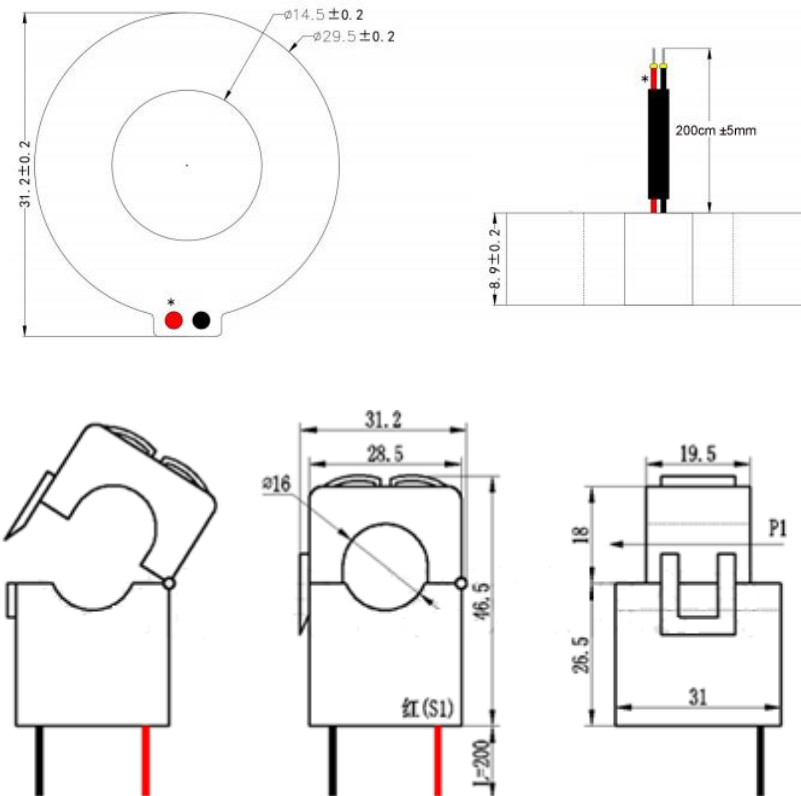

2.2、 Terminal definition and wiring

terminal	definition	illustrate	terminal	definition	illustrate
UA	A phase voltage input		A	RS485 positive pole	
UB	B phase voltage input		B	RS485 negative pole	
UC	C phase voltage input				
UN	Neutral input		C O M	Switch function reserved	
			NO	Switch function reserved	
A+	A phase current transformer+		I N+	Residual current transformer+	
A-	A phase current transformer -		I N-	Residual current transformer-	
B+	B phase current transformer+				
B-	B phase current transformer-				
C+	C phase current transformer+				
C-	C phase current transformer-				

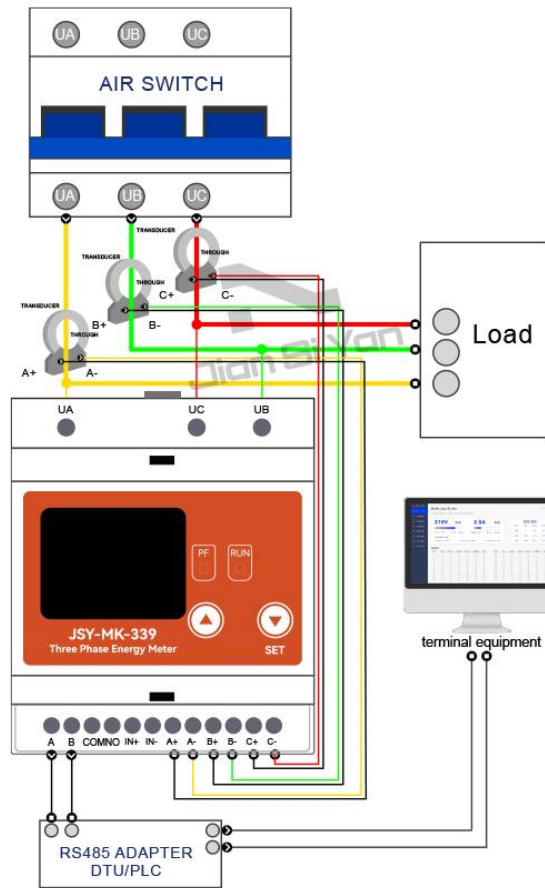

Three Phase Three Wire

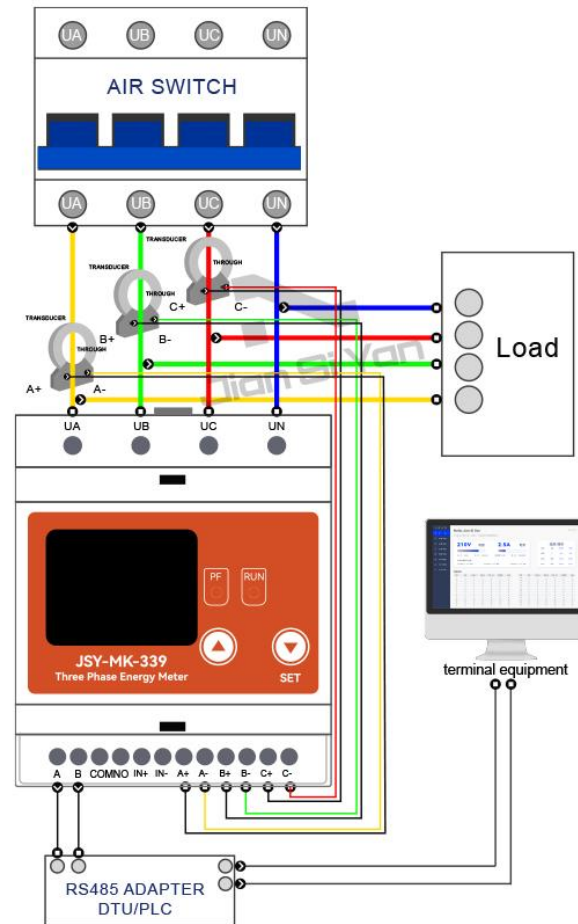

Three Phase Four Wire

2.3、 Application Notes

Please refer to the above diagram for correct wiring according to product specifications and models. Make sure to disconnect all signal sources before wiring to avoid danger and damage to the equipment. After checking to confirm that the wiring is correct, turn on the power and test.

After the power is turned on, the "power " operating indicator light is always on, and the "communication" indicator light flashes synchronously during communication data transmission.

When the products leave the factory, they are set to the default configuration: address No. 1, baud rate 96 00bps, data format "n,8,1", data update rate is 1000ms, and transformation ratio is 1.

You can use the JSY-MK-301 product testing software we provide to change the settings of product parameters and general testing of the product.

2.4.1、 RS-485 network connection:

The host generally only has an RS - 232 interface. At this time, it can be connected to the 485 network through an RS - 232/ RS -485 converter. It is recommended to use an isolated 485 converter to improve the reliability of the system.

The A+ terminals of all devices on a bus are connected in parallel, and the B- terminals are connected in parallel. They cannot be connected in reverse. Up to 255 network instruments can be connected to one line at the same time. Each network instrument can set its communication address. The communication connection should use With shielded twisted pair, the wire diameter is not less than 0.5mm². When wiring, communication lines should be kept away from strong current cables or other strong electric field environments .

RS - 485 communication lines should use shielded twisted pairs. the communication distance of 485 can reach 1200 meters. When there are many RS485 devices connected to a bus , or when a higher baud rate is used, the communication distance will be shortened accordingly. At this time, you can Expand using 485 repeater.

RS - 485 networking has a variety of topologies, and generally uses linear connection, that is, starting from the upper host, multiple devices are connected to the network one by one from near to far. A terminal matching resistor of 120 ~ 300 Ω /0.25 watt can be connected at the farthest end (it depends on the specific communication quality, that is, it

does not need to be installed when the communication is very good).

2.4.2、 Electric energy measurement function:

Can provide three-phase voltage, current, power, power factor, active energy and other parameters.

The electricity data is a 4-byte unsigned number. It will not overflow for 10 consecutive years and the data will be saved when the power is turned off.

3. JSY-MK-339 Modbus register list

Table 1: Measuring electrical parameter register and communication data table (function code 03H to read, function code 10H to write)

serial number	Register address	Number of bytes	read/write	Function	illustrate
0	0x0000	2	read	model	Model, value is 0x339
1	0x0001	2	read	Hardware version	0x1001
2	0x0002	2	read	Software version	0x1001
3	0x0003	2	read	Protocol version	0x1001
4	0x0004	2	read	Rated voltage	250V value is 0x00FA
5	0x0005	2	read	Rated current	100A value is 0x0064

6	0x0006	2	read/write	RS485 address and baud rate	<p>The high bit is the address, the default is 0x01. the value is 0106H. the default address is 01H, the default communication format is 8, N, 1,9600bps</p> <p>Description: The 8 bits of the high byte are the address, 1~255. 0 is the broadcast address. the low byte is Baud rate, 5-4800bps, 6-9600bps, 7-19200bps</p>
7	0x000B	2	read	Alarm clear	Writing 0x0000 will clear the alarm, writing other values will have no effect.
8	0x000C 0x000D		Write	power clearing	Writing 0x0000 clears all energy registers, writing other values is invalid.

Three-phase electrical parameter register list

serial number	Register address		read/write	Function	illustrate
1	0x0048	2	read	A phase voltage	Unsigned number, value=DATA/100. unit V
2	0x0049	2	read	B phase voltage	Unsigned number, value=DATA/100. unit V
3	0x004A	2	read	C phase voltage	Unsigned number, value=DATA/100. unit V
4	0x004B	2	read	A phase current	Unsigned number,

					value=DATA/100. unit A
5	0x004C	2	read	B phase current	Unsigned number, value=DATA/100. unit A
6	0x004D	2	read	C phase current	Unsigned number, value=DATA/100. unit A
7	0x004E	2	read	Leakage current	Unsigned number, value=DATA/10000. unit A
8	0x004F	2	read	Phase A active power	Unsigned number, value=DATA/100. unit kW
9	0x0050	2	read	B phase active power	Unsigned number, value=DATA/100. unit kW
10	0x0051	2	read	C phase active power	Unsigned number, value=DATA/100. unit kW
11	0x0052	2	read	total active power	Unsigned number, value=DATA/100. unit kW
12	0x0053	2	read	Phase A reactive power	Unsigned number, value=DATA/100. unit kVar
13	0x0054	2	read	Phase B reactive power	Unsigned number, value=DATA/100. unit kVar
14	0x0055	2	read	C phase reactive power	Unsigned number, value=DATA/100. unit kVar
15	0x0056	2	read	total reactive power	Unsigned number, value=DATA/100. unit kVar
16	0x0057	2	read	Phase A apparent power	Unsigned number, value=DATA/100. unit kVar
17	0x0058	2	read	B phase apparent power	Unsigned number, value=DATA/100. unit kVar
18	0x0059	2	read	C phase apparent power	Unsigned number, value=DATA/100. unit kVar
19	0x005A	2	read	total apparent power	Unsigned number, value=DATA/100. unit kVar

20	0x005B	2	read	A phase power factor	Unsigned number, value=DATA/1000
twenty one	0x005C	2	read	B phase power factor	Unsigned number, value=DATA/1000.
twenty two	0x005D	2	read	B phase power factor	Unsigned number, value=DATA/1000.
twenty three	0x005E	2	read	Total power factor	Unsigned number, value=DATA/1000.
twenty four	0x005F	4	read	Phase A cumulative active power	Unsigned number, value=DATA/100. unit kWh, four bytes
25	0x0061	4	read	Phase B cumulative active energy	Unsigned number, value=DATA/100. unit kWh, four bytes
26	0x0063	4	read	Phase C cumulative active energy	Unsigned number, value=DATA/100. unit kWh, four bytes
27	0x0065	4	read	Total accumulated active power	Unsigned number, value=DATA/100. unit kWh, four bytes
28	0x0067	4	read	Phase A accumulated reactive power	Unsigned number, value=DATA/100. unit kVarh, four bytes
29	0x0069	4	read	Phase B accumulated reactive power	Unsigned number, value=DATA/100. unit kVarh, four bytes
30	0x006B	4	read	Phase C	Unsigned number,

				accumulated reactive power	value=DATA/100. unit kVarh, four bytes
31	0x006D	4	read	Total accumulated reactive power	Unsigned number, value=DATA/100. unit kVarh, four bytes
32	0x006F	4	read	Phase A cumulative apparent power	Unsigned number, value=DATA/100. unit kVah, four bytes
33	0x0071	4	read	Phase B cumulative apparent power	Unsigned number, value=DATA/100. unit kVah, four bytes
34	0x0073	4	read	Phase C cumulative apparent power	Unsigned number, value=DATA/100. unit kVah, four bytes
35	0x0075	4	read	Total accumulated apparent power	Unsigned number, value=DATA/100. unit kVah, four bytes
36	0x0077	2	read	frequency	Unsigned number, value=DATA/100. unit Hz

4. MODBUS communication protocol

This instrument provides a serial asynchronous half-duplex RS485 communication interface, using the standard MODBUS-RTU protocol, and various data information can be transmitted on the communication line. Up to 255 network instruments can be connected to one line at the same time. Each network instrument can set its communication address. The communication connection should use a shielded twisted pair with a copper mesh, and the wire diameter should not be less than 0.5mm². When wiring, communication lines should be kept away from strong current cables or other strong electric field environments.

The MODBUS protocol adopts the master-slave response communication connection

method on one communication line. First, the signal from the host computer is addressed to a terminal device (slave) with a unique address. Then, the response signal from the terminal device is transmitted to the host in the opposite direction, that is, the signal is transmitted along a separate communication line. All communication data streams are transmitted in opposite directions (half-duplex operating mode). The MODBUS protocol only allows communication between the host (PC, PLC, etc.) and terminal devices, but does not allow data exchange between independent terminal devices. In this way, each terminal device will not occupy the communication line when they are initialized, but is limited to responding. Query signal arriving at this machine.

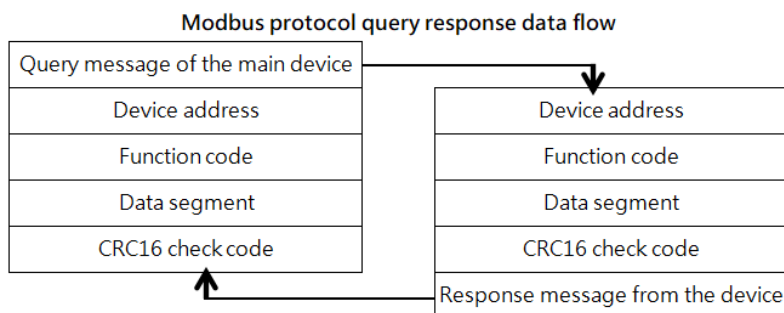

Host query: The query message frame includes device address, function code, data information code, and check code. The address code indicates the slave device to be selected. the function code tells the selected slave device what function to perform. For example, function code 03 or 04 requires the slave device to read registers and return their contents. the data segment contains the slave device requirements. Any additional information that performs functions. The check code is used to verify the correctness of a frame of information. The slave device provides a method to verify whether the message content is correct. It uses the calibration rule of CRC16.

Slave response: If the slave device generates a normal response, the response message contains the slave address code, function code, data information code and CRC16 check code. Data information codes include data collected from the device: like register values or status. If an error occurs, we agree that the slave machine will not respond.

We specify the communication data format used in this instrument: bits per byte (1 start bit, 8 data bits, odd or even parity or no parity, 1 or 2 stop bits) .

The structure of the data frame, that is, the message format:

Device address	function code	data segment	CRC16 check code
1 byte	1 byte	N bytes	2 bytes (low byte first)

Device address: It consists of one byte. The address of each terminal device must be unique. Only the addressed terminal will respond to the corresponding query.

Function code: tells the addressed terminal what function to perform. The following table lists the function codes supported by this series of instruments and their functions.

function code	Function
03H	Read the value of one or more registers
10H	Write the value of one or more registers
01H	Read the output status of relay 1
05H	Write the output status of relay 1

Data segment: Contains the data required by the terminal to perform specific functions or the data collected when the terminal responds to queries. The content of these data may be numerical values, reference addresses or setting values.

Check code: CRC16 occupies two bytes and contains a 16-bit binary value. The CRC value is calculated by the transmitting device and then appended to the data frame. The receiving device recalculates the CRC value when receiving the data and then compares it with the value in the received CRC field. If the two values are not equal, an error occurs. mistake.

The process of generating a CRC16 is:

- (1) Preset a 16-bit register to 0FFFFH (all 1s), called CRC register.
- (2) Perform XOR operation on the 8 bits of the first byte in the data frame and the low byte in the CRC register, and store the result back into the CRC register.
- (3) Shift the CRC register one bit to the right, fill the highest bit with 0, shift out the lowest bit and detect it.
- (4) If the lowest bit is 0: repeat the third step (next shift). if the lowest bit is 1: perform an XOR operation on the CRC register and a preset fixed value (0A001H).



- (5) Repeat steps 3 and 4 until 8 shifts. In this way, a complete eight bits are processed.
- (6) Repeat steps 2 to 5 to process the next eight bits until all bytes are processed.
- (7) The final value of the CRC register is the value of CRC16.

MODBUS-RTU communication protocol example:

4.1. Function code 0x03: Read multiple registers

Example: The host wants to read 2 slave register data with address 01 and start address 0048H.

Host sends: 01 03 00 48 00 02 CRC

Address function code starting address data length CRC code

Slave response: 01 03 04 12 45 56 68 CRC

Address function code returns the number of bytes Register data 1 Register data 2 CRC code

4.2. Function code 0x10: Write multiple registers

Example: The host wants to save 0000,0000 to the slave register with addresses 000C, 000D (slave address code is 0x01)

Host sends: 01 10 00 0C 00 02 04 00 00 00 00 F3 FA

Address function code starting address number of write registers byte count saved data 1 2 CRC code

Slave response: 01 10 00 0C 00 02 81 CB

Address function code starting address write register number CRC code

4.3. Function code 00x01: Read the status of 1 switch output

Example: The host wants to read the output status of the A-phase relay (the slave address code is 0x01)

Host sends: 01 01 00 00 00 01 CRC

The starting bit of the address function code reads the switch quantity CRC code

Slave response: 01 01 01 01 CRC

Address function code data length status data CRC code

4.4. Function code 0x05: Write 1 relay

The control command is: "FF00" means the output switch value is "1", that is, the control relay is "closed". "0000" means the output switch value is "0", that is, the control relay is "open".

Example: The host wants to control the phase A relay to "close" (slave address is 0x01)

Host sends: 01 05 00 00 FF 00 8C 3A

Address function code output bit control command CRC code

Slave response: exactly the same as the message and data content sent by the host

4.5. Description

The register in the MODBUS-RTU communication protocol refers to 16 bits (ie 2 bytes), and the high-order bit is first.

When setting parameters, be careful not to write illegal data (that is, data values that exceed the data range limit).

The error code format returned by the slave is as follows:

Address code: 1 byte

Function code: 1 byte (the highest bit is 1)

Error code: 1 byte

CRC: 2 bytes

The response returns the following error code:

81: Illegal function code, that is, the received function code module does not support it.

82: Reading or writing illegal data address, that is, the data location exceeds the readable or writable address range of the module.

83: Illegal data value, that is, the data value sent by the module received by the host exceeds the data range of the corresponding address.

Examples of communication messages

4.6.1 Read data register (function code 03H): Read the three register values of phase A.

The result is: voltage 231.5V, current 10.123A, power 2343W, instrument address is 1.

Host reads data frame:

address	Order	Starting address (high bit first)	Number of registers (high end first)	Check code (low digit first)
01H	03H	00H,48H	00H,03H	85H,DDH

The instrument responds with a data frame:

address	Order	Data length	Data segment (6 bytes)	Check code
01H	03H	06H	5AH,6EH,27H,8BH,09H,27H	F8H,92H

4.6.2 Write data register (function code 10H): Set the upper limit of phase A voltage to 260V, the upper limit of phase A current to 50A, and the instrument address to 1.

Host writes data frame:

addr ess	Order	starting address	Number of registers	Number of bytes	data segment	Check code
01H	10H	00H,20H	00H,02H	04H	01H,04H, 01H,F4H	B1H,9DH

The instrument responds with a data frame:

address	Order	starting address	Number of registers	Check code
01H	10H	00H,20H	00H,02H	40H,02H

5. Precautions

- 1) Pay attention to the auxiliary power information on the product label. Do not connect the wrong auxiliary power level and polarity of the product, otherwise the product may be damaged.
- 2) Please refer to the diagram for correct wiring according to product specifications and models. Make sure to disconnect all signal sources and power before wiring to avoid danger and damage to the equipment. After checking to confirm that the wiring is correct, turn on the power and test.
- 3) The voltage circuit or the secondary circuit of the PT must not be short-circuited.
- 4) When there is current on the primary side of the CT, it is strictly forbidden to open the secondary circuit of the CT. it is strictly forbidden to make live connections or unplug terminals.
- 5) When using the product in an environment with strong electromagnetic interference, please pay attention to the shielding of the input and output signal lines.
- 6) When installed in a centralized manner, the minimum installation interval should not be less than 10mm.

- 7) This series of products does not have a lightning protection circuit inside. When the input and output feeders of the module are exposed to harsh outdoor weather conditions, lightning protection measures should be taken.
- 8) Please do not damage or modify the product's label or logo, and do not disassemble or modify the product, otherwise our company will no longer provide "three guarantees" (guaranteed replacement, guaranteed return, and guaranteed repair) service for the product.

Manufacturer: Shenzhen Jiansiyan Technologies Co., Ltd.

Online Technical Support Staff:

+86 18675534520(Mr.Jahleel)

+86 18665924579(Mr.Jimmy)

E-mail: jsykj@outlook.com

Web: www.jsypowermeter.com

Address: 901, Building 1, Tajjiale Technology Industrial Park, Tongguan Road, Tianliao Community, Yutang Street, Guangming District, Shenzhen, Guangdong, 518100, China.



official website